

# DIN Rail Mounting Power Supply

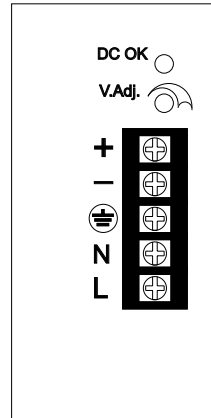
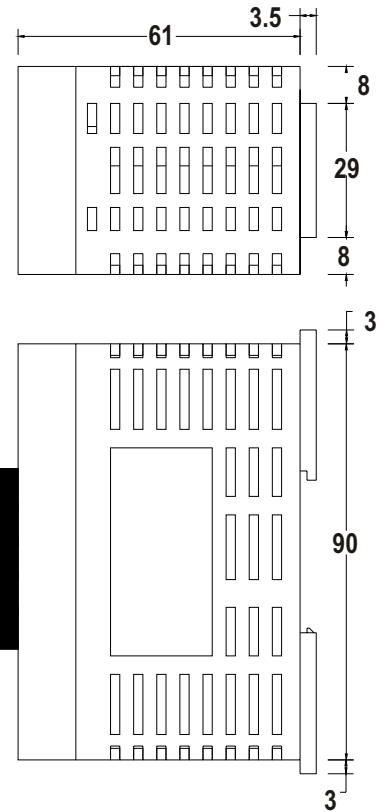

## INPUT

Input voltage .....100~240VAC/120~370VDC  
 Input frequency.....47~63Hz  
 Inrush current .....22A/115VAC  
 (Cold start) 44A/230VAC

## OUTPUT

Hold-up time (Full load@230VAC) .....20mS Min.  
 Over voltage protection .....Autorecovery  
 Overload protection .....Power limited  
 Short circuit protection .....Autorecovery

Dimensions:75(D)x96(H)x45(W)mm

## AD1024F Series

### Single output

Model	O/P voltage Adjustment	Loading (A) Min. Rated Max.	Ripple Noise	Line Reg.	Load Reg.	Eff.	O.V.P.	Redundant Function	MOQ	CB	UL	TUV
AD1020-05F	+5VDC±10%	0A 4A 4A	50mVp-p	±1%	±1%	78%	7VDC Max.	None	None	Yes	Yes	Yes
AD1024-12F	+12VDC±10%	0A 2A 2A	100mVp-p	±1%	±1%	80%	20VDC Max.	None	None	Yes	Yes	Yes
AD1024-24F	+24VDC±10%	0A 1A 1A	150mVp-p	±1%	±1%	83%	40VDC Max.	None	None	Yes	Yes	Yes

## AD1048FS Series

### Single output

Model	O/P voltage Adjustment	Loading (A) Min. Rated Max.	Ripple Noise	Line Reg.	Load Reg.	Eff.	O.V.P.	Redundant Function	MOQ	CB	UL	TUV
AD1048-12FS	+12VDC±10%	0A 4A 4A	100mVp-p	±1%	±1%	80%	20VDC Max.	None	None	Yes	Yes	Yes
AD1048-15FS	+15VDC±10%	0A 3A 3A	150mVp-p	±1%	±1%	80%	20VDC Max.	None	None	Yes	Yes	Yes
AD1048-24FS	+24VDC±10%	0A 2A 2A	150mVp-p	±1%	±1%	83%	40VDC Max.	None	None	Yes	Yes	Yes

- NOTE:**
1. Each output can supply up to maximum current, but total loading can not exceed rated output wattage.
  2. Line regulation is measured from low line to high line at rated load.
  3. Load regulation is measured from 20% to 100% of rated load at 230VAC input.
  4. Ripple & Noise is measured by using a 0.1uF/630V metalized capacitor & a 47uF electrolytic capacitor parallel on the test point, at rated load and 230VAC input.
  5. Efficiency is measured at rated load and 230VAC input.

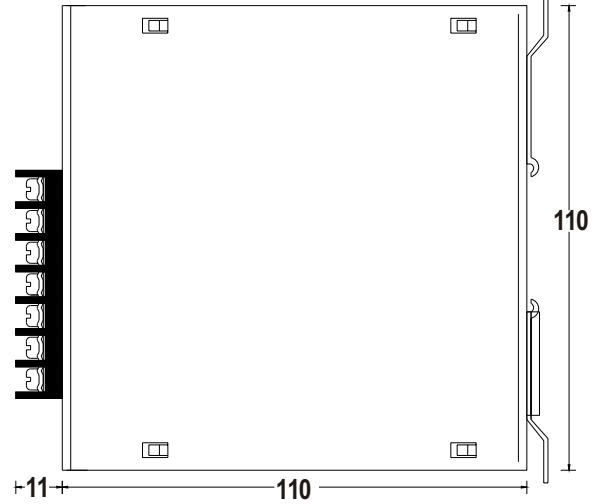
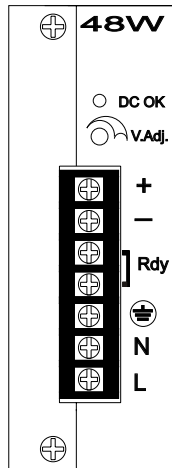
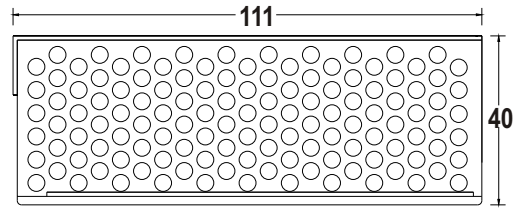

Dimensions: 121(D)x110(H)x40(W)mm

## INPUT

Input voltage .....100~240VAC/120~370VDC  
 Input frequency.....47~63Hz  
 Inrush current .....22A/115VAC  
 (Cold start) 44A/230VAC

## OUTPUT

Hold-up time (Full load@230VAC) .....20mS Min.  
 Over voltage protection .....Autorecovery  
 Overload protection .....Power limited  
 Short circuit protection .....Autorecovery

### AD1048F Series

#### Single output

Model	O/P voltage Adjustment	Loading (A) Min. Rated Max.	Ripple Noise	Line Reg.	Load Reg.	Eff.	O.V.P.	Redundant Function	MOQ	CB	UL	TUV
AD1040-05F	+5VDC±10%	0A 8A 8A	50mVp-p	±1%	±1%	78%	7VDC Max.	Option	None	Yes	None	None
AD1048-12F	+12VDC±10%	0A 4A 4A	100mVp-p	±1%	±1%	80%	17VDC Max.	Option	None	Yes	Yes	None
AD1048-24F	+24VDC±10%	0A 2A 2A	150mVp-p	±1%	±1%	83%	30VDC Max.	Option	None	Yes	Yes	None

### AD1060F Series

#### Single output

Model	O/P voltage Adjustment	Loading (A) Min. Rated Max.	Ripple Noise	Line Reg.	Load Reg.	Eff.	O.V.P.	Redundant Function	MOQ	CB	UL	TUV
AD1060-24F	+24VDC±10%	0A 2.5A 2.5A	150mVp-p	±1%	±1%	83%	30VDC Max.	Option	None	None	None	None

### AD2060F Series

#### Dual output

Model	O/P voltage Adjustment	Loading (A) Min. Rated Max.	Ripple Noise	Line Reg.	Load Reg.	Eff.	O.V.P.	Redundant Function	MOQ	CB	UL	TUV
AD20601F	+5VDC ±10%	0A 4A 5A	60mVp-p	±2%	±2%	77%	7VDC Max.	None	None	None	None	None
	+12VDC -----	0A 3A 3A	150mVp-p	±6%	±6%		-----					
AD20602F	+5VDC ±10%	0A 2A 5A	60mVp-p	±2%	±2%	80%	7VDC Max.	None	None	None	None	None
	+24VDC -----	0A 2A 2A	150mVp-p	±6%	±6%		-----					
AD20603F	+12VDC ±10%	0A 2A 4A	100mVp-p	±2%	±2%	81%	17VDC Max.	None	200pcs	None	None	None
	+24VDC -----	0A 1.5A 2A	150mVp-p	±6%	±6%		-----					

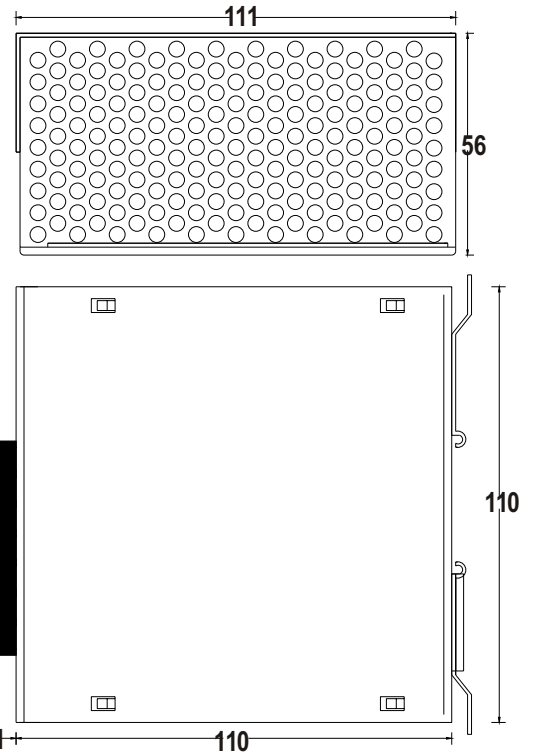

Dimensions: 121(D)x110(H)x56(W)mm

### INPUT

Input voltage .....100~240VAC/120~370VDC  
 Input frequency.....47~63Hz  
 Inrush current .....22A/115VAC  
 (Cold start) 44A/230VAC

### OUTPUT

Hold-up time (Full load@230VAC) .....20mS Min.  
 Over voltage protection .....Autorecovery  
 Overload protection .....Power limited  
 Short circuit protection .....Autorecovery

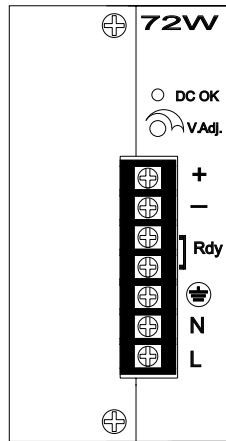

## AD1072F Series Single output

Model	O/P voltage Adjustment	Loading (A) Min. Rated Max.	Ripple Noise	Line Reg.	Load Reg.	Eff.	O.V.P.	Redundant Function	MOQ	CB	UL	TUV
AD1072-12F	+12VDC±10%	0A 6A 6A	100mVp-p	±1%	±1%	78%	17VDC Max.	Option	None	Yes	Yes	None
AD1072-24F	+24VDC±10%	0A 3A 3A	150mVp-p	±1%	±1%	81%	30VDC Max.	Option	None	Yes	Yes	None
AD1072-48F	+48VDC±10%	0A 1.5A 1.5A	250mVp-p	±1%	±1%	82%	56VDC Max.	Option	None	Yes	None	None

## AD1100F Series Single output

Model	O/P voltage Adjustment	Loading (A) Min. Rated Max.	Ripple Noise	Line Reg.	Load Reg.	Eff.	O.V.P.	Redundant Function	MOQ	CB	UL	TUV
AD1100-12F	+12VDC±10%	0A 8A 8A	100mVp-p	±1%	±1%	78%	17VDC Max.	Option	None	Yes	Yes	None
AD1100-24F	+24VDC±10%	0A 4A 4A	150mVp-p	±1%	±1%	81%	30VDC Max.	Option	None	Yes	Yes	None
AD1100-48F	+48VDC±10%	0A 2A 2A	250mVp-p	±1%	±1%	82%	56VDC Max.	Option	None	Yes	None	None

## AD2100F Series Dual output

Model	O/P voltage Adjustment	Loading (A) Min. Rated Max.	Ripple Noise	Line Reg.	Load Reg.	Eff.	O.V.P.	Redundant Function	MOQ	CB	UL	TUV
AD21001F	+12VDC ±10%	0A 7A 7A	100mVp-p	± 1%	± 2%	77%	17VDC Max.	None	200pcs	None	None	None
	+5VDC -----	0A 3A 3A	60mVp-p	± 2%	± 2%		-----					
AD21002F	+24VDC ±10%	0A 3.5A 3.5A	150mVp-p	± 1%	± 2%	80%	30VDC Max.	None	None	None	None	None
	+5VDC -----	0A 3A 3A	60mVp-p	± 2%	± 2%		-----					



## INPUT

Input voltage .....100~240VAC/120~370VDC  
 Input frequency.....47~63Hz  
 Inrush current .....22A/115VAC  
 (Cold start) 44A/230VAC

## OUTPUT

Hold-up time (Full load@230VAC) .....20mS Min.  
 Over voltage protection .....Autorecovery  
 Overload protection .....Power limited  
 Short circuit protection .....Autorecovery

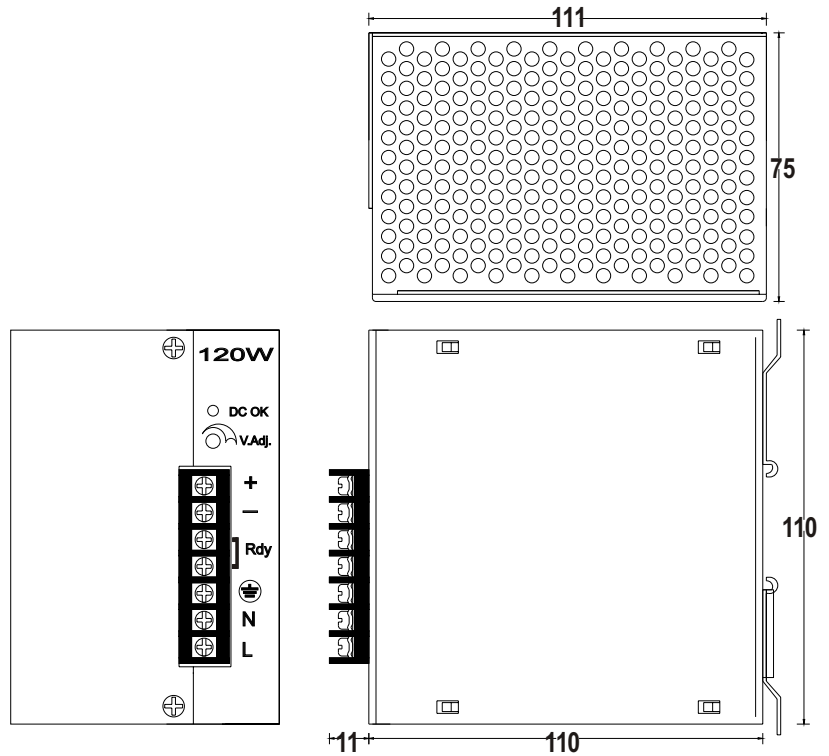

Dimensions:121(D)x110(H)x75(W)mm

### AD1120F Series

### Single output

Model	O/P voltage Adjustment	Loading (A) Min. Rated Max.	Ripple Noise	Line Reg.	Load Reg.	Eff.	O.V.P.	Redundant Function	MOQ	CB	UL	TUV
AD1120-12F	+12VDC±10%	0A 10A 10A	100mVp-p	± 1%	± 1%	78%	17VDC Max.	Option	None	Yes	Yes	None
AD1120-24F	+24VDC±10%	0A 5A 5A	150mVp-p	± 1%	± 1%	81%	30VDC Max.	Option	None	Yes	Yes	None
AD1120-48F	+48VDC±10%	0A 2.5A 2.5A	250mVp-p	± 1%	± 1%	82%	56VDC Max.	Option	None	Yes	Yes	None

### AD1150F Series

### Single output

Model	O/P voltage Adjustment	Loading (A) Min. Rated Max.	Ripple Noise	Line Reg.	Load Reg.	Eff.	O.V.P.	Redundant Function	MOQ	CB	UL	TUV
AD1150-12F	+12VDC±10%	0A 12.5A 12.5A	100mVp-p	± 1%	± 1%	78%	17VDC Max.	Option	None	Yes	Yes	None
AD1150-24F	+24VDC±10%	0A 6.3A 6.3A	150mVp-p	± 1%	± 1%	81%	30VDC Max.	Option	None	Yes	Yes	None
AD1150-48F	+48VDC±10%	0A 3.2A 3.2A	250mVp-p	± 1%	± 1%	82%	56VDC Max.	Option	None	Yes	Yes	None

### AD2150F Series

### Dual output

Model	O/P voltage Adjustment	Loading (A) Min. Rated Max.	Ripple Noise	Line Reg.	Load Reg.	Eff.	O.V.P.	Redundant Function	MOQ	CB	UL	TUV
AD21501F	+12VDC ±10%	0A 11A 11A	100mVp-p	± 1%	± 2%	78%	17VDC Max.	None	200pcs	None	None	None
	+5VDC -----	0A 3A 3A	60mVp-p	± 2%	± 2%		-----					
AD21502F	+24VDC ±10%	0A 5.5A 5.5A	150mVp-p	± 1%	± 2%	80%	30VDC Max.	None	None	None	None	None
	+5VDC -----	0A 3A 3A	60mVp-p	± 2%	± 2%		-----					

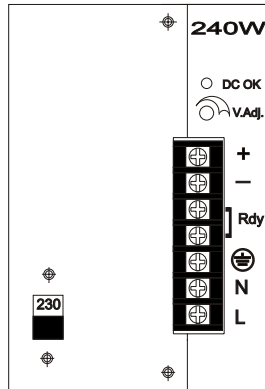
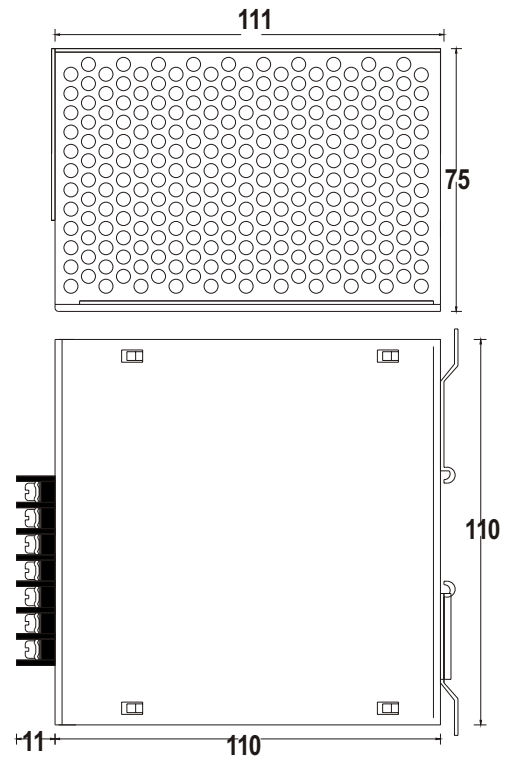

Dimensions: 121(D)x110(H)x75(W)mm

## INPUT

Input voltage .....115/230VAC selectable  
 Input frequency.....47~63Hz  
 Inrush current .....22A/115VAC  
 (Cold start) 44A/230VAC

## OUTPUT

Hold-up time (Full load@230VAC) .....20mS Min.  
 Over voltage protection .....Autorecovery  
 Overload protection .....Power limited  
 Short circuit protection .....Autorecovery

### AD1240S Series

#### Single output

Model	O/P voltage Adjustment	Loading (A) Min. Rated Max.	Ripple Noise	Line Reg.	Load Reg.	Eff.	O.V.P.	Redundant Function	MOQ	CB	UL	TUV
AD1240-12S	+12VDC±10%	0A 20A 20A	100mVp-p	± 1%	± 1%	80%	17VDC Max.	Option	None	Yes	Yes	None
AD1240-24S	+24VDC±10%	0A 10A 10A	150mVp-p	± 1%	± 1%	82%	30VDC Max.	Option	None	Yes	Yes	None
AD1240-48S	+48VDC±10%	0A 5A 5A	250mVp-p	± 1%	± 1%	82%	56VDC Max.	Option	None	Yes	Yes	None

### AD1360S Series

#### Single output

Model	O/P voltage Adjustment	Loading (A) Min. Rated Max.	Ripple Noise	Line Reg.	Load Reg.	Eff.	O.V.P.	Redundant Function	MOQ	CB	UL	TUV
AD1360-24S	+24VDC±10%	0A 15A 15A	100mVp-p	± 1%	± 1%	82%	30VDC Max.	Option	None	Yes	Yes	None

### AD2240S Series

#### Dual output

Model	O/P voltage Adjustment	Loading (A) Min. Rated Max.	Ripple Noise	Line Reg.	Load Reg.	Eff.	O.V.P.	Redundant Function	MOQ	CB	UL	TUV
AD22402S	+24VDC ±10%	0A 9A 9A	150mVp-p	± 1%	± 2%	82%	30VDC Max.	None	200pcs	None	None	None
	+5VDC -----	0A 3A 3A	60mVp-p	± 2%	± 2%		-----					
AD22403S	+48VDC ±10%	0A 4.5A 4.5A	250mVp-p	± 1%	± 2%	82%	56VDC Max.	None	200pcs	None	None	None
	+5VDC -----	0A 3A 3A	60mVp-p	± 2%	± 2%		-----					

# DIN Rail Mounting Power Supply

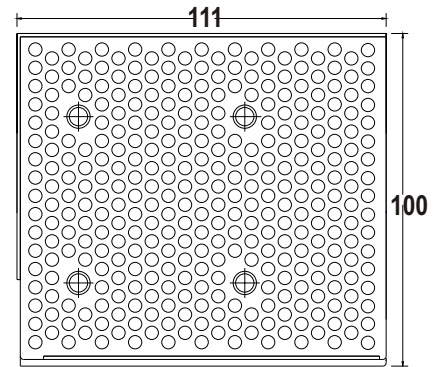

## INPUT

Input voltage .....100~240VAC/120~370VDC  
 Input frequency.....47~63Hz  
 Inrush current .....22A/115VAC  
 (Cold start) 44A/230VAC  
 Active PFC .....PF>0.94

## OUTPUT

Hold-up time (Full load@230VAC) .....20mS Min.  
 Over voltage protection .....Autorecovery  
 Overload protection .....Power limited  
 Short circuit protection .....Autorecovery

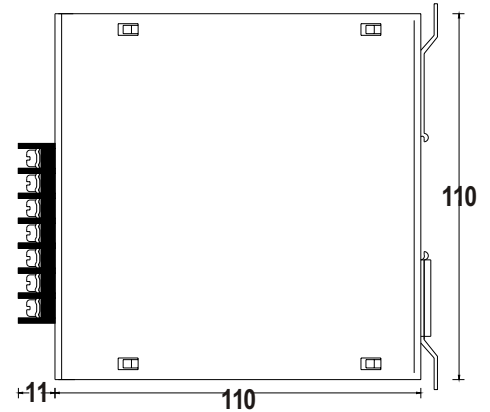
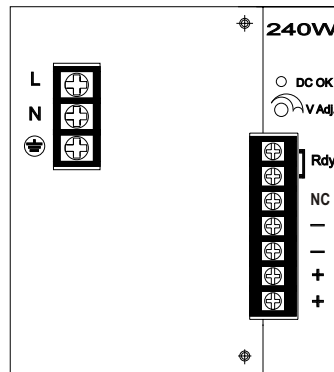

Dimensions:121(D)x110(H)x100(W)mm

## AD1240C Series

### Single output

Model	O/P voltage Adjustment	Loading (A) Min. Rated Max.	Ripple Noise	Line Reg.	Load Reg.	Eff.	O.V.P.	Redundant Function	MOQ	CB	UL	TUV
AD1240-12C	+12VDC±10%	0A 20A 20A	100mVp-p	± 1%	± 1%	80%	17VDC Max.	Option	None	Yes	Yes	None
AD1240-24C	+24VDC±10%	0A 10A 10A	150mVp-p	± 1%	± 1%	82%	30VDC Max.	Option	None	Yes	Yes	None
AD1240-48C	+48VDC±10%	0A 5A 5A	250mVp-p	± 1%	± 1%	82%	56VDC Max.	Option	None	Yes	Yes	None

## AD1360C Series

### Single output

Model	O/P voltage Adjustment	Loading (A) Min. Rated Max.	Ripple Noise	Line Reg.	Load Reg.	Eff.	O.V.P.	Redundant Function	MOQ	CB	UL	TUV
AD1360-12C	+12VDC±10%	0A 30A 30A	100mVp-p	± 1%	± 1%	80%	17VDC Max.	Option	None	Yes	Yes	None
AD1360-24C	+24VDC 10%	0A 15A 15A	150mVp-p	± 1%	± 1%	82%	30VDC Max.	Option	None	Yes	Yes	None
AD1360-48C	+48VDC 10%	0A 7.5A 7.5A	250mVp-p	± 1%	± 1%	82%	56VDC Max.	Option	None	Yes	Yes	None

## AD2240C Series

### Dual output

Model	O/P voltage Adjustment	Loading (A) Min. Rated Max.	Ripple Noise	Line Reg.	Load Reg.	Eff.	O.V.P.	Redundant Function	MOQ	CB	UL	TUV
AD22402C	+24VDC±10%	0A 9A 9A	150mVp-p	± 1%	± 2%	82%	30VDC Max.	None	100pcs	None	None	None
	+5VDC -----	0A 3A 3A	60mVp-p	± 2%	± 2%							
AD22403C	+48VDC±10%	0A 4.5A 4.5A	250mVp-p	± 1%	± 2%	82%	56VDC Max.	None	100pcs	None	None	None
	+5VDC -----	0A 3A 3A	60mVp-p	± 2%	± 2%							

## AD2360C Series

## Dual output

Model	O/P voltage Adjustment	Loading (A) Min. Rated Max.	Ripple Noise	Line Reg.	Load Reg.	Eff.	O.V.P.	Redundant Function	MOQ	CB	UL	TUV
AD23602C	+24VDC $\pm 10\%$	0A 14A 14A	150mVp-p	$\pm 1\%$	$\pm 2\%$	82%	30VDC Max.	None	100pcs	None	None	None
	+5VDC -----	0A 3A 3A	60mVp-p	$\pm 2\%$	$\pm 2\%$		-----					
AD23603C	+48VDC $\pm 10\%$	0A 7A 7A	250mVp-p	$\pm 1\%$	$\pm 2\%$	82%	56VDC Max.	None	100pcs	None	None	None
	+5VDC -----	0A 3A 3A	60mVp-p	$\pm 2\%$	$\pm 2\%$		-----					

### Product description

The DIN rail power supplies are designed to snap-on TS-35 DIN rail and wall bracket mounting. They are idea for use in control system, factory automation, industrial control, instrumentation, electromagnetic drivers and other DC load. The models are designed according to the latest requirement and standard that CE marking and RoHS compliance. Built-in dry contact rela and O-ring diode to offer Rdy (Alarm) signal and redundant application. Complete protection include over voltage, overload and short circuit to avoid damage.

### Terminal allocation

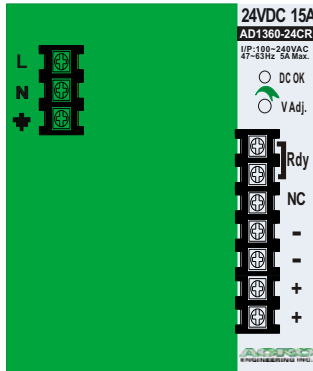

Designation	Description
DC OK	Green LED Indicator
V Adj.	O/P Voltage adjustment
NC	No connection
+	Output Positive
-	Output Negative
Rdy	DC OK signal (Short)
⊕	Earth
N	Input Neutral
L	Input Line

### Rdy & Redundant connection

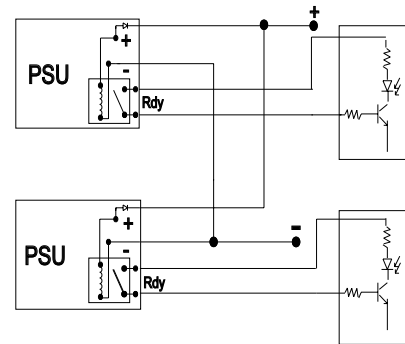

### Model No. Description

Family .....	AD	(DIN rail)
Number of Output.....	1	(Single)
	2	(Dual)
Rated Output Wattage.....	360	(360W)
Rated Output Voltage.....	24	(24VDC)
Developing sequency.....	2	(2nd model)
Input Voltage Range.....	C	(100~240VAC)
Redundant & Rdy function.....	R	(with function)

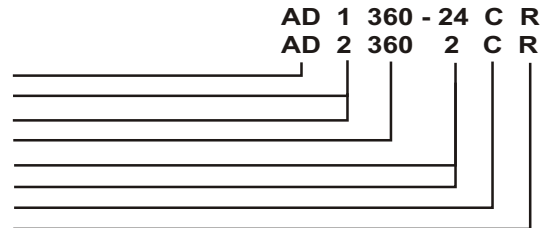

### Installation Instruction

1. Making sure wire connection of the designations before turn on AC source. The connector can withstand 8 lb-in torque maximum and use copper connectors only, 60/75°C and installation in Pollution Degree 2 environment. Max. surrounding air temperature 40°C.
2. Snap power unit on TS35 DIN rail, please remove upper mounting bracket and operate as Fig. 2. Using a "+" screw driver to pull down underside mounting bracket to release power unit from TS35 DIN rail.
3. The left housing of power unit is design as heatsink, please keep 15mm Min. for dissipating heating. (Fig. 1)
4. For mounting power unit by mounting bracket, please loosen screws on mounting bracket and pull both brackets outer. And then re-screw the mounting brackets to get easier operation of mounting on wall/plate. (Fig. 3)
5. Output voltage adjustable range is +/-10% of rated voltage, over +10% might cause over voltage protection, under 10% might cause output flicking at lower loading.

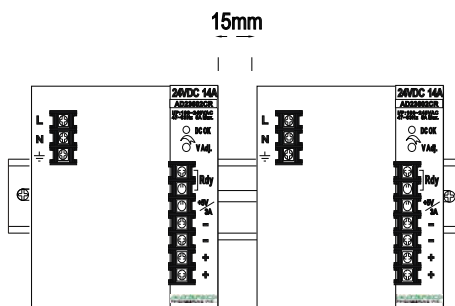

Fig. 1

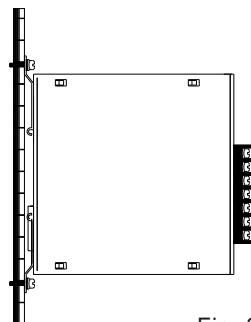

Fig. 3

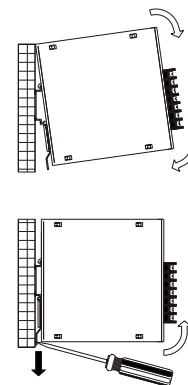
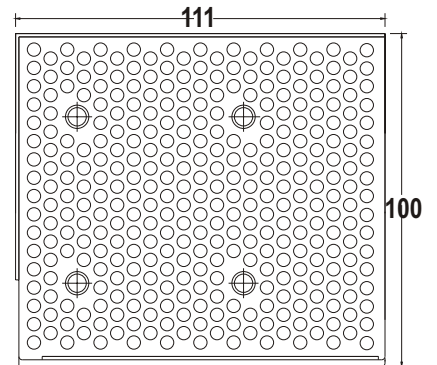

Fig. 2



## INPUT

Input voltage .....115/230VAC selectable  
 Input frequency.....47~63Hz  
 Inrush current .....22A/115VAC  
 (Cold start) 44A/230VAC

## OUTPUT

Hold-up time (Full load@230VAC) .....20mS Min.  
 Over voltage protection .....Autorecovery  
 Overload protection .....Power limited  
 Short circuit protection .....Autorecovery

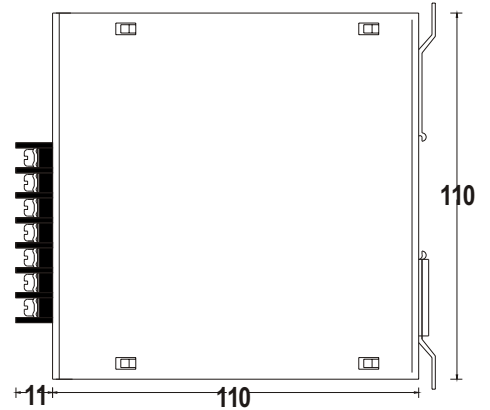
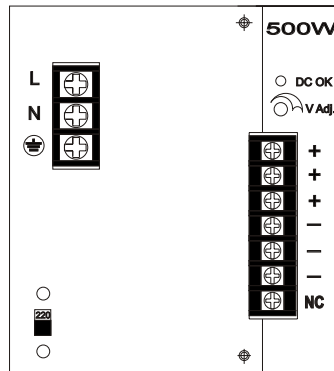

Dimensions:121(D)x110(H)x100(W)mm

## AD1500S Series

### Single output

Model	O/P voltage Adjustment	Loading (A) Min. Rated Max.	Ripple Noise	Line Reg.	Load Reg.	Eff.	O.V.P.	Redundant Function	MOQ	CB	UL	TUV
AD1500-24S	+24VDC±10%	0A 21A 21A	150mVp-p	± 1%	± 1%	85%	30VDC Max.	Option	None	Yes	Yes	None
AD1500-48S	+48VDC±10%	0A 10.5A 10.5A	250mVp-p	± 1%	± 1%	85%	56VDC Max.	Option	None	Yes	Yes	None

## AD2500S Series

### Dual output

Model	O/P voltage Adjustment	Loading (A) Min. Rated Max.	Ripple Noise	Line Reg.	Load Reg.	Eff.	O.V.P.	Redundant Function	MOQ	CB	UL	TUV
AD25002S	+24VDC±10%	0A 20A 20A	150mVp-p	± 1%	± 2%	85%	30VDC Max.	None	100pcs	None	None	None
	+5VDC -----	0A 3A 3A	60mVp-p	± 2%	± 2%		-----					
AD25003S	+48VDC±10%	0A 10A 10A	250mVp-p	± 1%	± 2%	85%	56VDC Max.	None	100pcs	None	None	None
	+5VDC -----	0A 3A 3A	60mVp-p	± 2%	± 2%		-----					

- NOTE:**
1. Each output can supply up to maximum current, but total loading can not exceed rated output wattage.
  2. Line regulation is measured from low line to high line at rated load.
  3. Load regulation is measured from 20% to 100% of rated load at 230VAC input.
  4. Ripple & Noise is measured by using a 0.1uF/630V metalized capacitor & a 47uF electrolytic capacitor parallel on the test point, at rated load and 230VAC input.
  5. Efficiency is measured at rated load and 230VAC input.